

United  
States  
of  
America

To Promote the Progress

of Science and Useful Arts

The Director

of the United States Patent and Trademark Office has received an application for a patent for a new and useful invention. The title and description of the invention are enclosed. The requirements of law have been complied with, and it has been determined that a patent on the invention shall be granted under the law.

Therefore, this United States

Patent

grants to the person(s) having title to this patent the right to exclude others from making, using, offering for sale, or selling the invention throughout the United States of America or importing the invention into the United States of America, and if the invention is a process, of the right to exclude others from using, offering for sale or selling throughout the United States of America, products made by that process, for the term set forth in 35 U.S.C. 154(a)(2) or (c)(1), subject to the payment of maintenance fees as provided by 35 U.S.C. 41(b). See the Maintenance Fee Notice on the inside of the cover.

Katherine Kelly Vidal

DIRECTOR OF THE UNITED STATES PATENT AND TRADEMARK OFFICE

## Maintenance Fee Notice

If the application for this patent was filed on or after December 12, 1980, maintenance fees are due three years and six months, seven years and six months, and eleven years and six months after the date of this grant, or within a grace period of six months thereafter upon payment of a surcharge as provided by law. The amount, number and timing of the maintenance fees required may be changed by law or regulation. Unless payment of the applicable maintenance fee is received in the United States Patent and Trademark Office on or before the date the fee is due or within a grace period of six months thereafter, the patent will expire as of the end of such grace period.

## Patent Term Notice

If the application for this patent was filed on or after June 8, 1995, the term of this patent begins on the date on which this patent issues and ends twenty years from the filing date of the application or, if the application contains a specific reference to an earlier filed application or applications under 35 U.S.C. 120, 121, 365(c), or 386(c), twenty years from the filing date of the earliest such application (“the twenty-year term”), subject to the payment of maintenance fees as provided by 35 U.S.C. 41(b), and any extension as provided by 35 U.S.C. 154(b) or 156 or any disclaimer under 35 U.S.C. 253.

If this application was filed prior to June 8, 1995, the term of this patent begins on the date on which this patent issues and ends on the later of seventeen years from the date of the grant of this patent or the twenty-year term set forth above for patents resulting from applications filed on or after June 8, 1995, subject to the payment of maintenance fees as provided by 35 U.S.C. 41(b) and any extension as provided by 35 U.S.C. 156 or any disclaimer under 35 U.S.C. 253.



US011870310B2

(12) **United States Patent**  
**Sinkhorn et al.**

(10) **Patent No.:** **US 11,870,310 B2**

(45) **Date of Patent:** **Jan. 9, 2024**

(54) **METHOD OF REPAIRING A HYDROGENERATOR**

(71) Applicant: **Electromechanical Engineering Associates, Inc.**, Monroeville, PA (US)

(72) Inventors: **Jason Sinkhorn**, Greensburg, PA (US); **J. Barry Sargeant**, DeLand, FL (US); **Lauren Haley**, Pittsburgh, PA (US); **Thomas Schildkamp**, Greensburg, PA (US)

(73) Assignee: **Electromechanical Engineering Associates, Inc.**, Monroeville, PA (US)

(\* ) Notice: Subject to any disclaimer, the term of this patent is extended or adjusted under 35 U.S.C. 154(b) by 158 days.

(21) Appl. No.: **16/974,278**

(22) Filed: **Dec. 14, 2020**

(65) **Prior Publication Data**  
US 2022/0190694 A1 Jun. 16, 2022

(51) **Int. Cl.**  
**H02K 15/00** (2006.01)  
**H02K 7/18** (2006.01)  
**H02K 1/30** (2006.01)  
**F03B 13/08** (2006.01)  
**G01N 29/04** (2006.01)  
**F16C 43/02** (2006.01)  
**F16C 17/04** (2006.01)

(52) **U.S. Cl.**  
CPC ..... **H02K 15/0006** (2013.01); **F03B 13/083** (2013.01); **F16C 43/02** (2013.01); **G01N 29/043** (2013.01); **H02K 1/30** (2013.01); **H02K 7/1823** (2013.01); **F05B 2230/80** (2013.01); **F16C 17/04** (2013.01); **F16C 2360/00** (2013.01); **G01N 2291/0289** (2013.01)

(58) **Field of Classification Search**

CPC ..... B23P 6/00; B23P 15/00; B23P 15/008; Y10T 29/9718; Y10T 29/49721; Y10T 29/4973; Y10T 29/49732; Y10T 29/4932; H02K 15/0006; H02K 1/30; H02K 7/1823; H02K 2213/06; F03B 13/083; F16C 43/02; F16C 17/04; F16C 2360/00; G01N 29/043; G01N 2291/0289; G01N 2291/2693; G01N 29/348; F05B 2230/80  
USPC .... 29/402.01, 402.03, 402.08, 402.09, 889.2  
See application file for complete search history.

(56) **References Cited**

**U.S. PATENT DOCUMENTS**

2,632,397 A \* 3/1953 Jandasek ..... F16H 41/28  
60/365  
3,727,848 A \* 4/1973 Francis ..... B02C 13/13  
241/197  
4,327,303 A \* 4/1982 Jacobsen ..... H02K 1/30  
310/423  
4,619,029 A \* 10/1986 Newell ..... B02C 19/0062  
29/402.08

(Continued)

*Primary Examiner* — David P Bryant

*Assistant Examiner* — Darrell C Ford

(74) *Attorney, Agent, or Firm* — Dentons Cohen & Grigsby P.C.

(57) **ABSTRACT**

A method for repairing an electric generator having a rotor that rotates about a vertical axis, the rotor including a spider having a number of spider arms extending radially away from the axis, and a rim surrounding the spider. The weight of the rim is normally carried at least in part by rim support ledges of the spider arms. The method for repair includes supporting the rim from the top of the spider and thereby relieving some or all of the weight of the rim being supported by the rim support ledges.

**11 Claims, 6 Drawing Sheets**

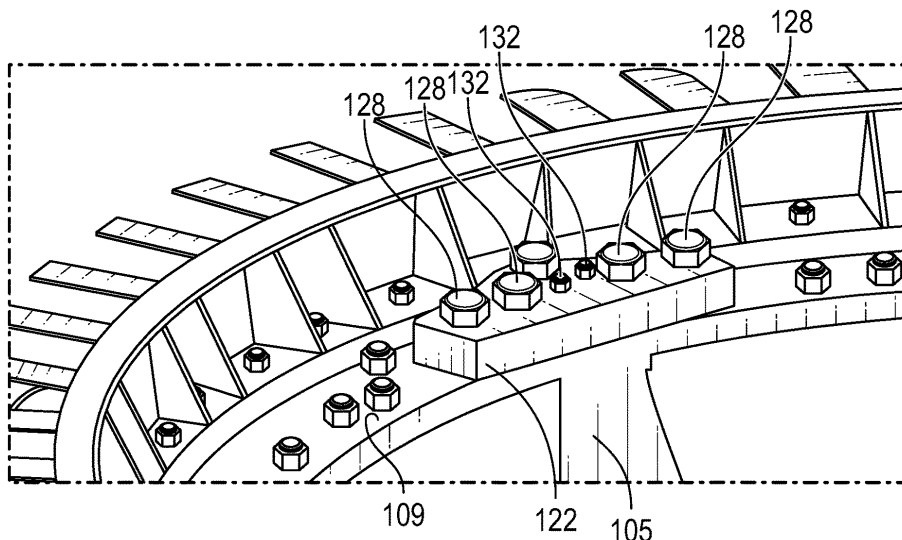

(56)

**References Cited**

U.S. PATENT DOCUMENTS

5,347,880 A \* 9/1994 Kallenberger ..... F16H 55/12  
74/447  
6,204,589 B1 \* 3/2001 Cascio ..... H02K 1/30  
310/74  
6,255,752 B1 \* 7/2001 Werner ..... F16C 32/0692  
310/90.5  
2004/0200057 A1 \* 10/2004 Maslov ..... H02K 1/187  
310/216.001  
2013/0187486 A1 \* 7/2013 Lee ..... H02K 1/30  
310/43  
2015/0101180 A1 \* 4/2015 Neumann ..... H02K 15/0006  
310/71  
2018/0375419 A1 \* 12/2018 Rebsdorf ..... H02K 55/04

\* cited by examiner

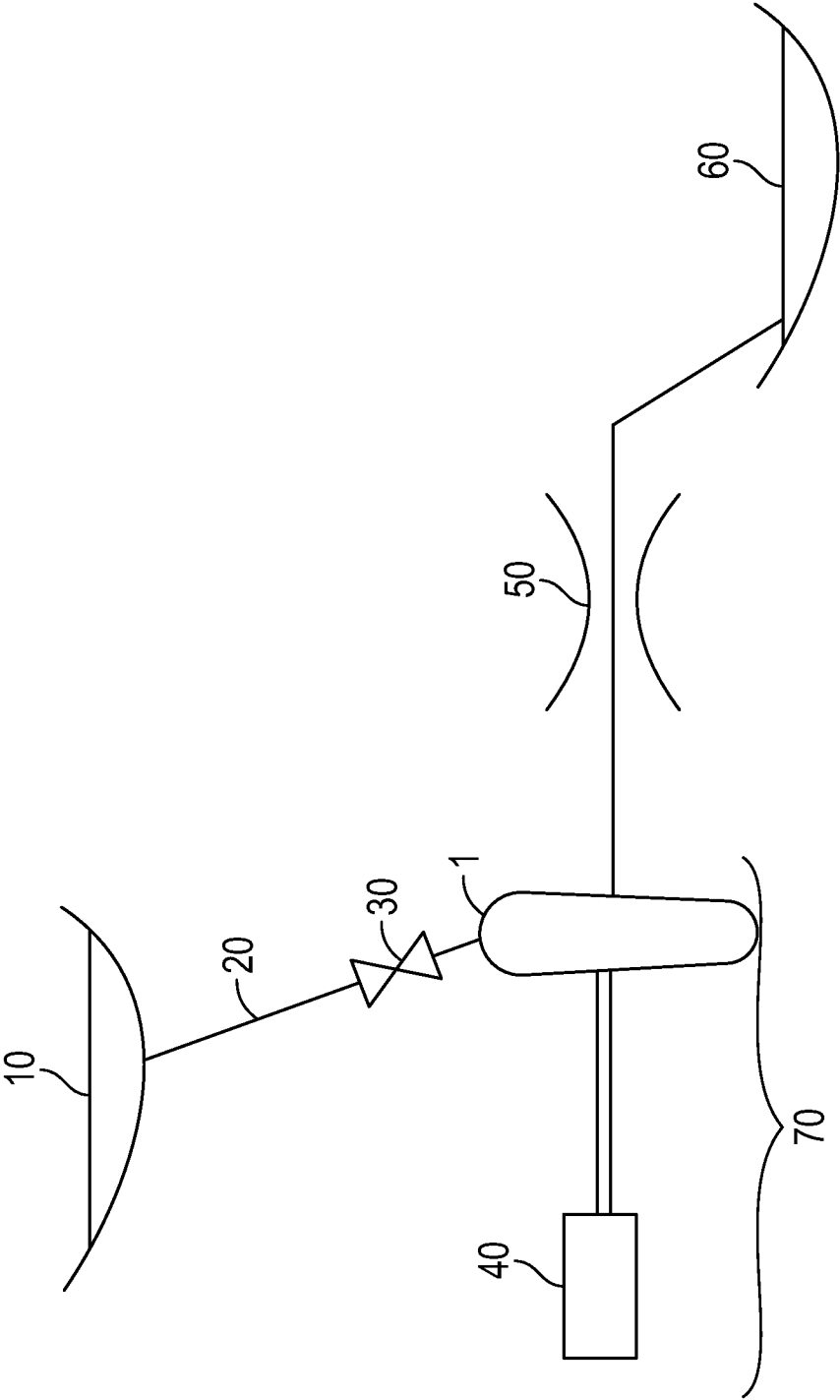
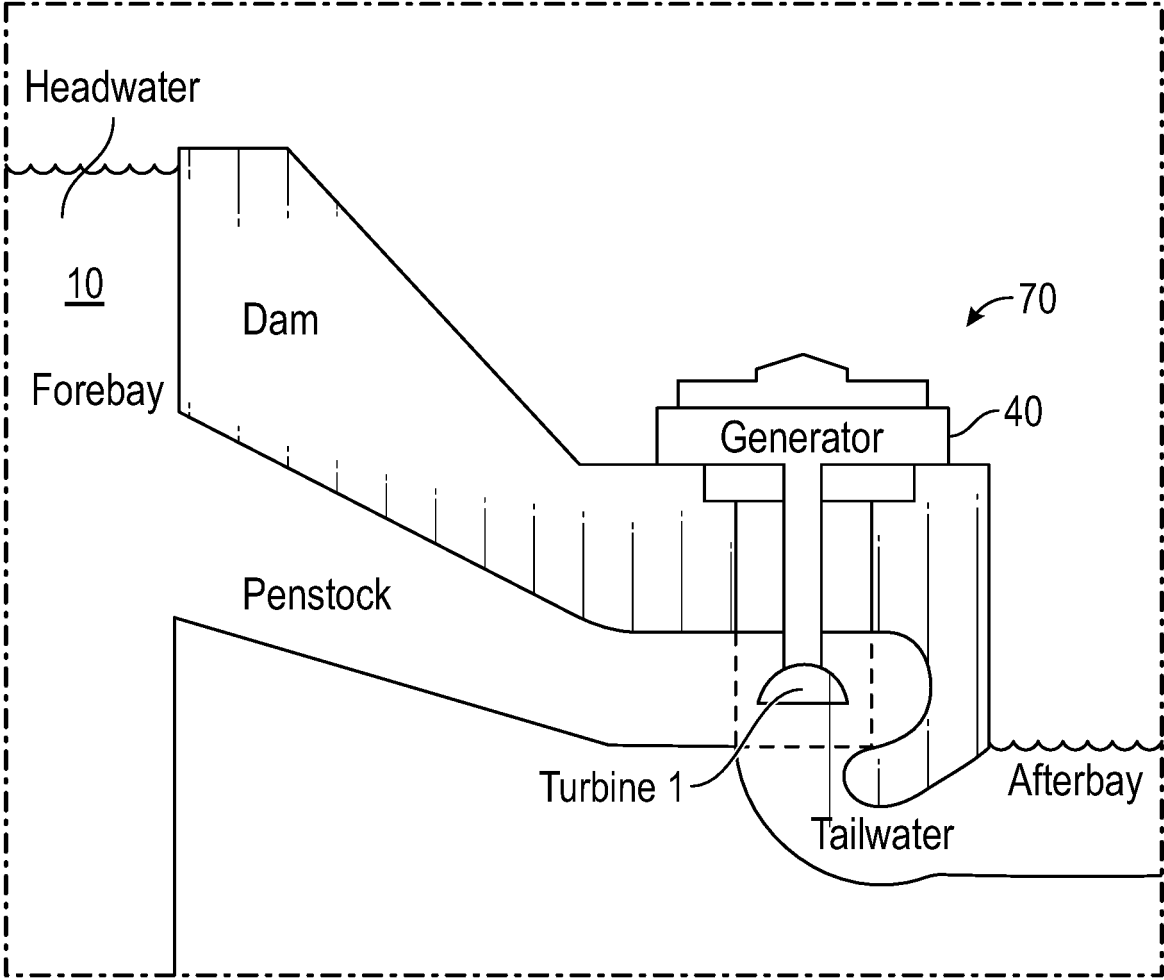

FIG. 1  
(Prior Art)



**FIG. 2**  
**(Prior Art)**

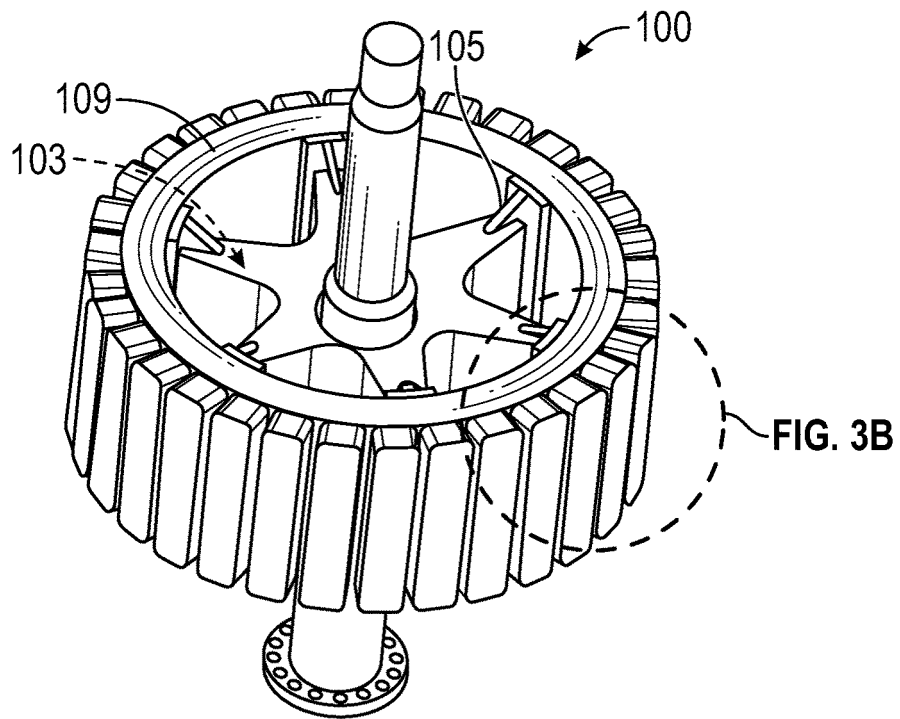

FIG. 3A  
(Prior Art)

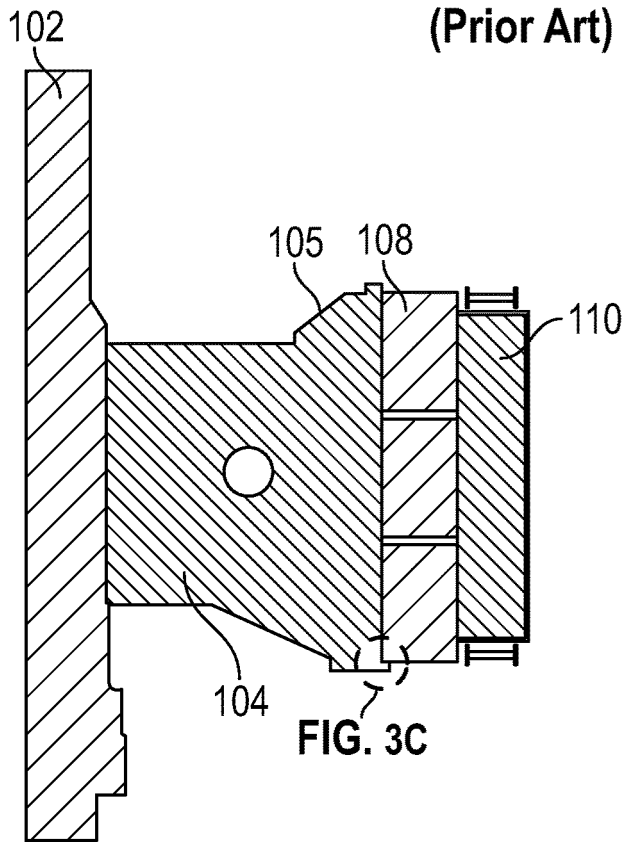

FIG. 3B  
(Prior Art)

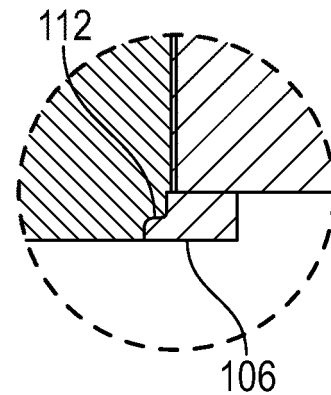

FIG. 3C  
(Prior Art)

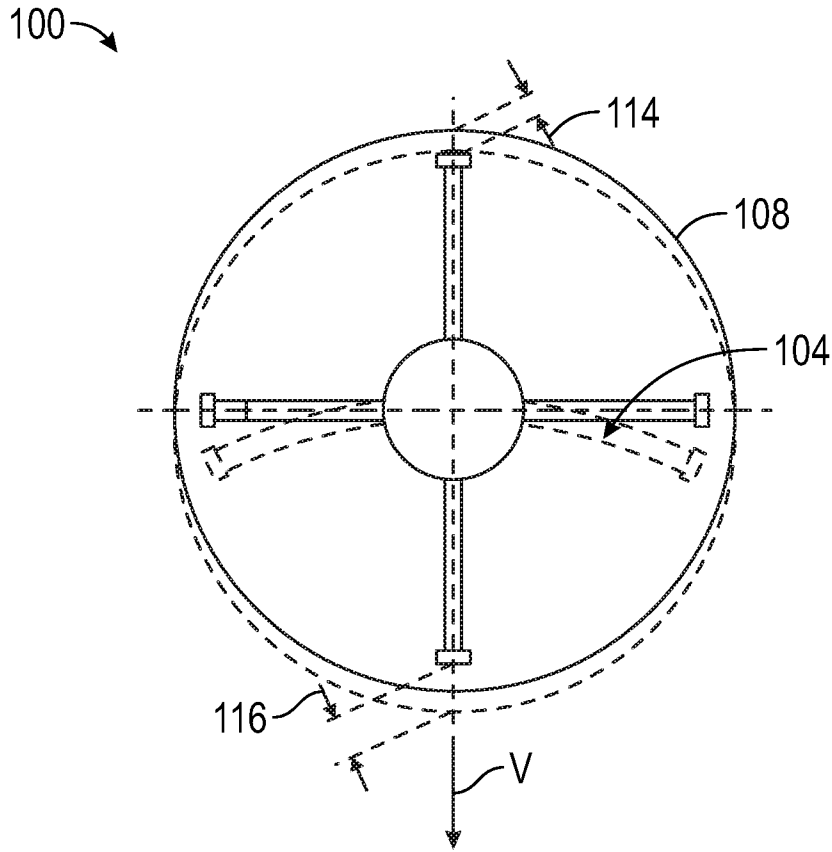

FIG. 4  
(Prior Art)

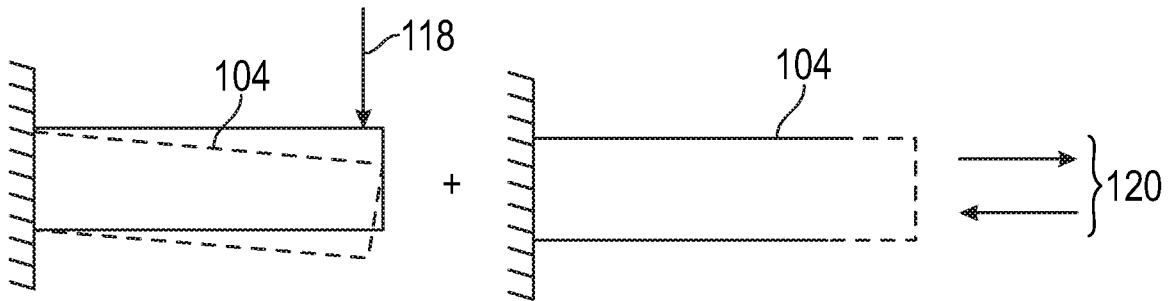

FIG. 5A  
(Prior Art)

FIG. 5B  
(Prior Art)



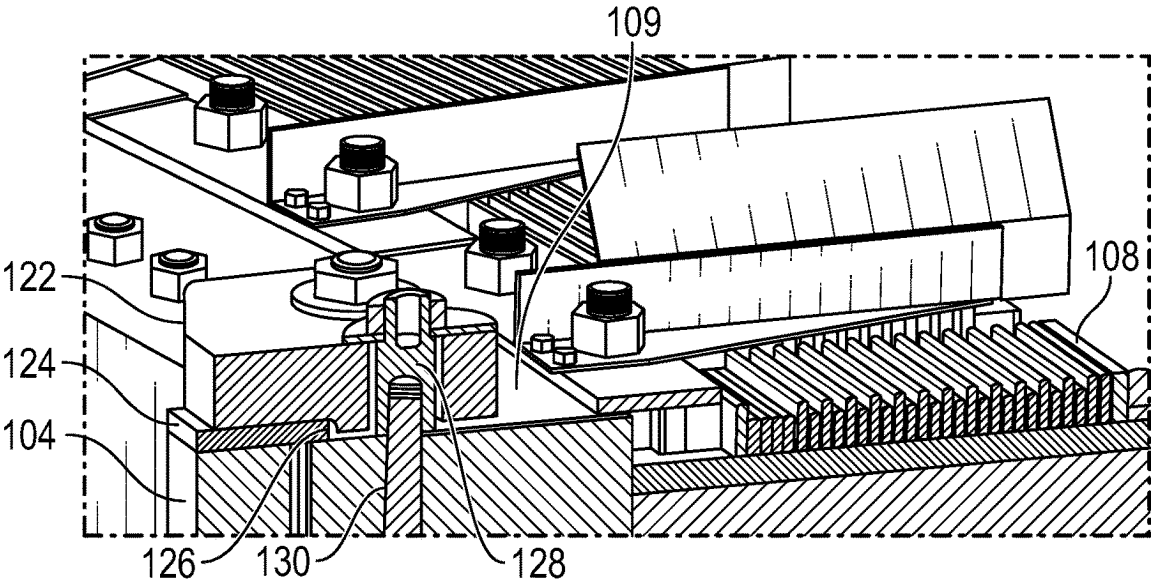

FIG. 6

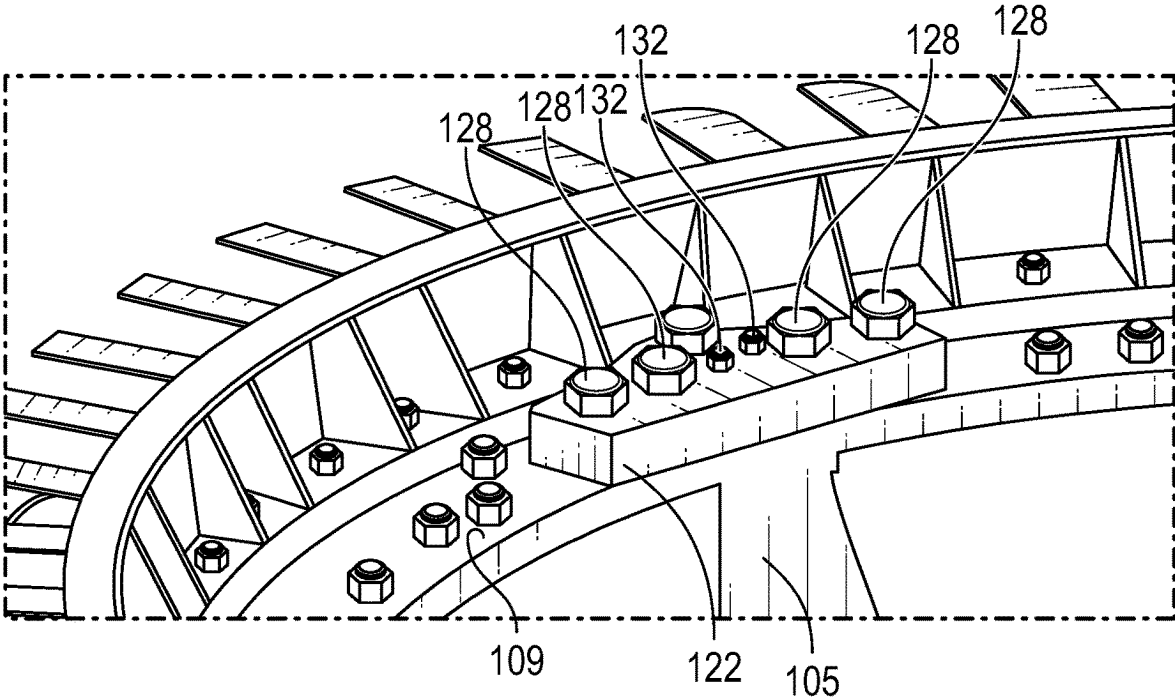

FIG. 7

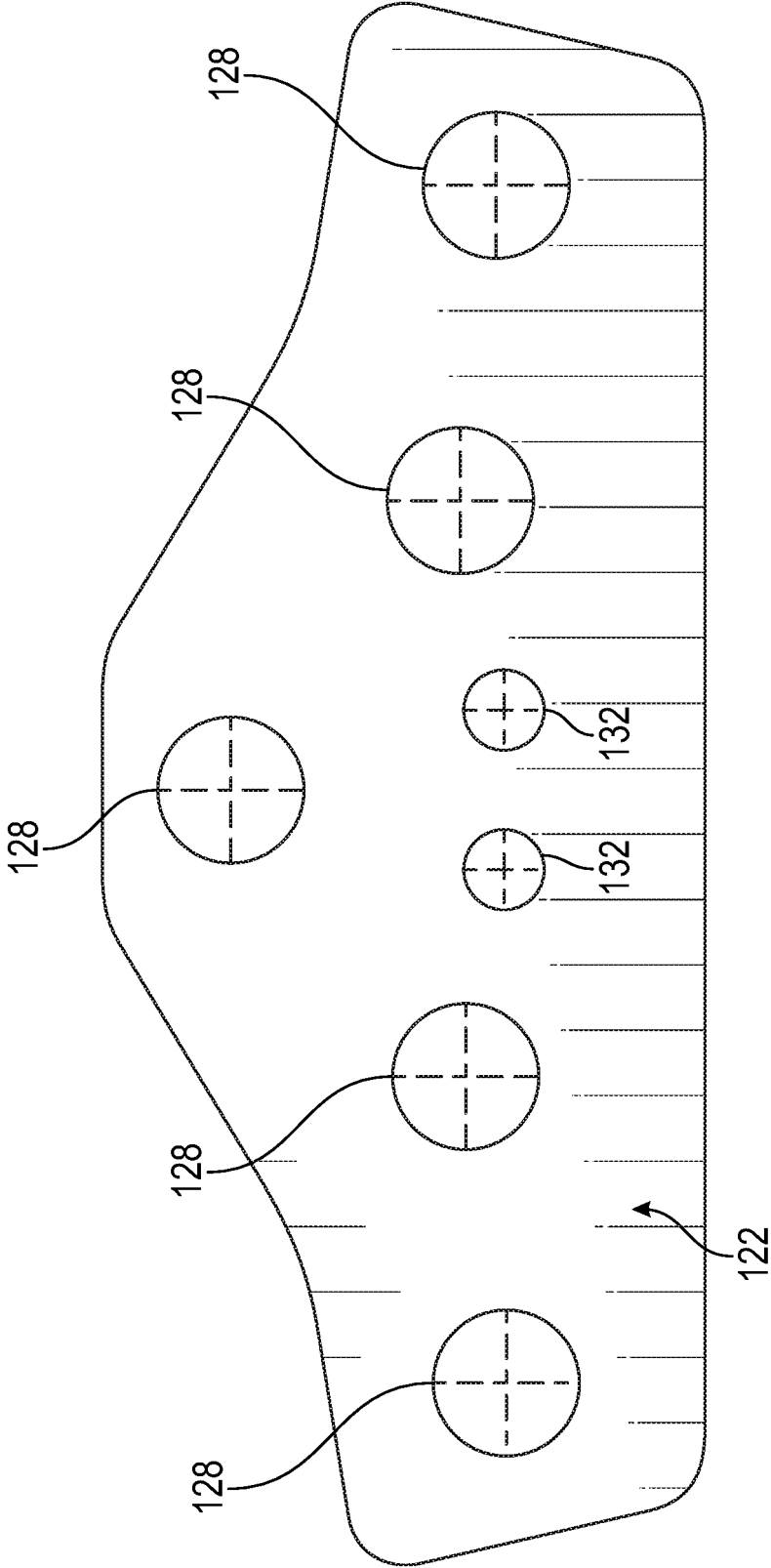

FIG. 8

1

## METHOD OF REPAIRING A HYDROGENERATOR

This application claims priority from related provisional application 62/948,021.

### FIELD OF THE DISCLOSURE

The present disclosure relates to a method of repairing a hydrogenerator.

### BACKGROUND OF THE DISCLOSURE

Background information is for informational purposes only and does not necessarily admit that subsequently mentioned information and publications are prior art.

Hydroelectric power comes from flowing water, for example, winter and spring runoff from mountain streams and clear lakes. Water, when it is falling by the force of gravity, can be used to turn turbines and generators that produce electricity.

At facilities called hydroelectric powerplants, hydro-power is generated. Some powerplants are located on rivers, streams, and canals, but for a reliable water supply, dams are needed. Dams store water for later release for such purposes as irrigation, domestic and industrial use, and power generation. The reservoir acts much like a battery, storing water to be released as needed to generate power.

FIG. 1 illustrates a hydropower plant that includes an upper body of water **10** feeding a turbine **1** through a pressure line **20** via a shutoff element **30**. The turbine **1** drives a generator **40** that generates electricity. The turbine **1** and the electric generator **40** together form a hydrogenerator (hydroelectric generator) **70**.

As shown in FIG. 2, a dam creates a reservoir forming the upper body of water **10**. The reservoir has a "head" or height from which water flows. A pipe (penstock) carries the water from the reservoir to the hydrogenerator **70**. The hydrogenerator **70** shown in FIG. 2 is a vertical hydrogenerator designed around a vertically mounted shaft assembly. Attached to the upper portion of the shaft assembly is a rotor **100** (see FIG. 3A) of the generator **40**. Attached to the lower end of the shaft is the turbine **1**. The turbine **1** has turbine blades driven by the fast-moving water from the penstock, something like a pinwheel in the wind. The turbine **1** drives the rotor **100** within a stator of the electric generator **70** to generate electricity.

FIG. 3A shows a rotor **100** of a typical electric generator **40**, and FIG. 3B shows a cross-section of the circled portion of the rotor **100** in FIG. 3A. The rotor **100** includes a shaft **102** and a spider **103** attached to the shaft **102**. The spider **103** supports a rim **108** surrounding the shaft **102**. The rim **108** carries a number of poles **110** spaced along the outer circumference of the rim **108**. When the poles **110** pass by poles in the stator during rotation of the rotor **100**, the electric generator **70** generates electricity.

The illustrated spider **103** is a welded steel structure having six spider arms **104** with vertical posts **105** at their ends that support the rim **108**. The rim **108** is a ring of laminated steel segments held together by solid steel end plates **109** at the top and bottom, and clamped together by bolts **130** (see FIG. 6) passing through the end plates and laminations. The rotor poles **110** in turn are supported by the rim **108** both radially, usually by dovetails, and axially by the rim **108**.

The weight of the rotor **100** and the rim **108** are supported on the vertical posts **105** of the spider arms **104**. Each

2

vertical post **105** is provided with a rim support ledge **106** machined in the base of the vertical post. FIG. 3C shows a close-up view of a rim support ledge **106** machined in the base of the vertical post **105**. In general, the rim **108** is supported on the rim support ledges **106**, and is mounted on the spider arms **104** by a friction fit.

A common problem that occurs in the operation of the electric generator **40** is that wear occurs at the rim support ledge **106** generally due to friction between the rim **108** and the rim support ledge **106**. Because of different operational forces and other factors, the rim **108** may move with respect to the rim support ledge **106**, which can ultimately lead to damage, such as the fracture **112** of the rim support ledge **106** illustrated in FIG. 3C.

Examples of operational forces that may cause the rim **108** to move with respect to one or more of the rim support ledges **106** include high frequency forces that may occur once or twice with each revolution of the rotor **100**: eccentricity (out of roundness) of the rotor **100**; and unbalanced magnetic forces that can distort the rim **108**.

An unbalanced magnetic pole vector **V** on the rotor **100** is shown in FIG. 4. The clearance **114** at the top of FIG. 4 is shown as the clearance with the rim **108** concentric. The eccentricity **116** at the bottom of FIG. 4 is shown as clearance with the rim **108** eccentric. The magnetic forces distort the rim **108** during operation whereby, because of the rim's construction in layers, fretting or other wear occurs which ultimately leads to the failure of some part of the rotor structure which then must be repaired. The lateral flexibility of the spider arms **104** plus the loss of frictional interference between the rim **108** and the spider arms **104** permits the rim **108** to slide on the ledges **106** at each start, and also once per revolution, when exposed to an unbalanced magnetic pole. It is very difficult if not impossible to build a hydrogenerator which does not have an unbalance magnetic pole. Even the slightest unbalance will cause the components of the rotor to move with respect to one another and cause fretting if not other wear on the rotor.

Examples of operational forces that may cause the rim **108** to move with respect to one or more of the rim support ledges **106** include low cycle forces that occur with start/stop of the hydrogenerator **70** or arise from transient operating conditions: radial expansion of the rim **108** caused by rotation of the rim **108**; differential radial expansion of the rim **108** caused by the rim **108** heating more than the spider **103** during operation; stopping and cooling of the rim **108** when the hydrogenerator **70** is shut down; and overspeed/runaway conditions, out-of-phase synchronizations, short circuits, and transient torque spikes.

FIG. 5A shows the force **118** of the dead weight of the rim **108** and the poles **110** pulling down on the spider arms **104**. FIG. 5B shows the traction (friction) force **120** from sliding, which forces combine to cause wear during operation. The dead weight of the rim **108** and the poles **110** will act upon components of the hydroelectric generator **70**. At each start and stop of the hydroelectric generator **70** there will be a centrifugal force on the generator rim **108**, thereby causing the components thereof to move with respect to one another. The movement of the components with respect to one another will cause or contribute in causing the fretting or other damage to the components of the rotor **100**, which will accelerate damage and the appearance of cracks in the structure of the rotor **100**.

In general, hydrogenerators often experience fatigue cracking of the rotor rim support ledges. The rim support ledges are where fatigue and wear caused by the relative movement of the rim can occur. The wear can produce

cracking and eventually even a complete fracture or breaking off of a rim support ledge. Since the ledges provide support for the rim, breakage of these ledges could result in significant damage to the rotor as a whole and individual components thereof, as well as any adjacent portions of the hydrogenerator.

The most common approaches to repair damaged rim support ledges are to either remove and then replace or refurbish the rim, or to provide supplemental supports beneath the rim or in the rim vent duct. Replacement or refurbishment is undesirable as it is very expensive, time-consuming, and requires complete removal or lifting of the rim. Supplemental supports beneath the rim are not usually able to carry the full load of the rim and have poor resistance to fatigue. Supplemental supports in the rim vent duct have the problems of not being applicable to all machines, difficulty in achieving load sharing, and having an indeterminate lifespan.

Thus, there is a need to provide a cost-effective repair method for hydrogenerators to extend the life span of a rim and spider of a rotor upon damage to the rim support ledges.

#### SUMMARY OF THE DISCLOSURE

Disclosed is a cost-effective repair method for hydrogenerators that extends the life span of a rim and spider of a rotor upon damage to the rim support ledges.

According to one possible embodiment, the repair method involves the rim being supported from the top of the spider posts instead of on the rim support ledges at the bottom of the spider posts. In general, support structures are attached to the tops of the spider posts to support the rim from above and relieve the weight on the rim support ledges.

Embodiments of the support structures are thrust plates formed from steel having sufficient strength to support the rim while preserving ductility and toughness for fatigue resistance. The thrust plates can be affixed to the rim with sleeve bolts that thread to the rim clamping studs. The sleeve bolts can be tightened periodically to compensate for wear of the thrust plates or to compensate for wear of wear plates placed below the thrust plates.

The disclosed method for repair hangs the rim from the top of the spider posts. The disclosed method has a number of advantages:

1. It replaces the rim ledge with a considerably stronger piece of material that is still ductile and has excellent fatigue resistance;
2. The support structures have a greatly reduced stress concentration at the corner of the support as compared to the rim ledges;
3. The support structures control the friction between the rim support and the spider post; and
4. The support structures reset the "fatigue cycles" counter to zero with respect to support of the rim on the spider.

#### BRIEF DESCRIPTION OF THE DRAWINGS

FIG. 1 shows a possible hydropower plant;  
 FIG. 2 is a diagram of how a hydropower plant works;  
 FIGS. 3A, 3B, and 3C show a typical geometry and failure location of a rotor;

FIG. 4 shows an unbalanced magnetic pole vector on a rotor;

FIG. 5A shows the dead weight of the rim and the poles of a rotor, and FIG. 5B shows the traction (friction) force from sliding.

FIGS. 6 and 7 show an embodiment of a thrust plate assembly for a hydrogenerator in place on the rotor shown in FIG. 3; and

FIG. 8 is a top view of the thrust plate of the thrust plate assembly shown in FIG. 7.

#### DETAILED DESCRIPTION

FIG. 6 shows a thrust plate assembly having a thrust plate **122** used in an embodiment of the disclosed method for repairing the electric generator **40** shown in FIGS. 3A and 3C as having a fractured rim support ledge **106**.

In general, in this embodiment a plurality of thrust plates **122** are located one at each of a corresponding spider arm **104**. The thrust plates **122** support the rim **108** from above on the spider arms **104**. In other words, instead of the weight of the rim **108** resting solely on the rim support ledges **106**, which one or more rim support ledges **106** are cracked or completely broken off, the weight of the rim **108** is supported by the thrust plates **122**, such that the rim **108** is, in a sense, hanging from the thrust plates **122**. The thrust plate **122** is spaced apart from the rim **108** itself.

In the illustrated embodiment a wear plate or sacrificial plate **124** is located in a recessed or stepped or shoulder portion **126** of the thrust plate **122** between the thrust plate **122** and the spider arm **104**. A portion of the wear plate **124** may or may not extend so as to be in contact with the top of the rim **108**. The spacing of the thrust plate **122** a distance from the rim **108** prevents frictional contact between the thrust plate **122** and the rim **108**, and thus prevents wear. Instead, the wear plate **124**, which is lubricated with a solid lubricant, experiences friction and wear.

As the wear plate **124** wears down, a sleeve bolt **128** can be tightened periodically to tighten the connection of the thrust plate **122**. In this manner, the life of the rotor **100** can be extended without extensive repairs or replacement.

The following discusses the installation, design, and function of the thrust plate **122** in greater detail. It should be noted that all numbers and materials specifically listed for different parts and components and measurements thereof are strictly in accordance with at least one possible embodiment and should not be understood as limiting the embodiments disclosed herein, as well as any reasonable variations or modifications thereof.

FIG. 7 illustrates mounting of a thrust plate **122** on the rim **108** adjacent to a spider arm vertical post **105**, and FIG. 8 illustrates the fasteners fastening the thrust plate **122** on the rim top plate **109**. The thrust plates **122** can be 3" (three inch) thick machined plates manufactured from ASTM A829 SAE **4140** with a minimum yield strength of 70 ksi, and a UTS not less than 118 ksi and a40% reduction in area. This provides strength while providing ductility and toughness for fatigue resistance. Each thrust plate **122** is affixed to the rim **108** with five sleeve bolts **128** that thread to the rim clamping studs **130** (see FIG. 6), and two 1.25" (one-and-one-quarter inch) alloy socket head cap screws **132**.

The sleeve bolts **128** are modeled for stress analysis as though a 2.75" (two- and three-quarters inch) Hex bolt with a suitable length of unthreaded shank were cut off, bored and tapped with 1.75"-5 UNC inside threads. The minimum tensile area of this configuration is slightly greater than that of the original stud. The sleeve bolts **128** are made from commercial Grade 5 bolts, and thus will be at least as strong as the rim studs **130**. The length below the heads will be 3" (three inches); then with the washers under the head, contact of the bottom of the shank with the rim top plate **109** will be avoided.

5

The two 1.25" (one-and-one-quarter inch) socket head cap screws **132** are used to resist localized bending due to the weight of the rim **108**. The design specification calls for a maximum of 1/3rd (one-third) of the rim weight to be carried by an individual thrust plate **122**. This is slightly over 33 tons for the illustrated rim, and though obviously could not be carried by all of the thrust plates **122**, could conceivably be carried by some of them. The rim top plate **109** must be drilled and tapped for the Helicoil thread insert corresponding to this thread.

Stress analysis (including the use of finite element models) and both high-cycle fatigue analysis and low cycle fatigue analysis of the thrust plate, rim top plate in the vicinity of its attachment to the thrust plate, and the loading of the fasteners attaching the transfer plate to the top of the rim were conducted. Stresses in the thrust plate, rim top plate in the vicinity of the attachment, and the loading of the socket head cap screws were evaluated. Because the rim **108** now hangs from the rim's top end plate **109**, stresses in the top end plate are impacted. Also impacted are rim compression and rim studs, which in addition to the clamping load now carry the weight of the rim in an area localized to the thrust plate installation.

Evaluation of the thrust plate, rim, rim top plate and attachment methods under very conservative loading assumptions show that the repair method applied to the rotor **100** will be suitable for at least a 5 year life, and very likely for a considerable period beyond this if necessary. The conditions necessarily used for evaluation were found to be conservative just as this report was being finalized. That is, it was found that the rotor rims were loose enough to be lifted off the spider arm support ledges. This more certainly fixes the spider post dead weight loading at 1x the rim weight as a steady load (up-thrusting is eliminated). It was therefore concluded that the thrust plate repair will be suitable for the service intended.

Further, in evaluating the application of the disclosed method for repair to a specific hydrogenerator, it may not be known if it is possible to lift the rim relative to the spider. This can result in a somewhat indeterminate loading situation. The rim would be leveled and the thrust plates would be assembled to a cold rim. At that point the transfer plates would be carrying little load. But as it is unclear how much load cracked ledges might bear (and clearly broken ledges would bear none), a complex load situation may be created. The loading scenario may be based on solid rim support ledges. In order to bound the possibilities of a lack of support from some of the ledges, the possible load on an arm may be increased (for example, doubled).

It may be that the rim could be lifted from the support ledges. This makes it possible to control the loading scenario so that the spider arms will carry only 1/6th (not 1/3rd) of the rim load each, as a steady load. With careful friction control, then, the stress ranges due to rim movement on the bearing surfaces may be lowered. As well, there will be no unloading of the rim weight as is posited in the low cycle fatigue scenario.

For some rotors, the spider is designed with uneven angular spacing of the rotor spider arms. Taken together, it appears that the intent was to make the rim as close to "elastically solid" as possible. That is to say that slipping between laminations, which would allow the rim to grow circumferentially leading to a loss of interference with the spider, is prevented (or attempted to be prevented) by high friction forces and close fitting of the clamping bolts to the holes in the laminations.

6

In evaluating application of the disclosed method for repair to a specific hydrogenerator, it may not be known if the hydrogenerator rim was designed to "float" duration operation. Hydro generators of similar construction have been designed with floating rims; however, rims utilizing an interference fit relative to the spider are more common. Regardless of the original design, it is accepted that the rim is now floating and likely has been for some time. That is, the rim outgrows the spider due to centrifugal forces and differential heating. This is a small amount of movement and ideally occurs only once per start/stop cycle. This movement creates an alternating "push-pull" on the rim support ledges that is imposed on the steady state stresses due to the dead weight of the rim and poles. Thus, a low cycle fatigue situation would likely exist even under ideal conditions just based on the design and construction, and the rim ledges should have been designed to withstand that scenario. Rim ledge cracking is ordinarily a high cycle fatigue problem caused by the normal imperfections of operation in combination with rim dead weight loading and the frictional forces on the rim ledge due to rim movement. These "normal imperfections" include such things as eccentricity of the rotor in the stator, unbalanced magnetic pull, and the elastic deformation of the rotor and stator. This causes the push-pull frictional forces noted above to increase in frequency from once or (a few times) per start-stop cycle to once or twice per revolution, a clearly different fatigue regime in which millions of cycles occur relatively quickly. As an example, suppose these machines were started and stopped once per day; then 365 cycles/year would occur. But if they were operated even 12 hours/day at 277 rpm, 457 million cycles would occur in 1 year.

It is impossible to avoid these forces to some degree in any hydro generator. Some manufacturers attempt to prevent the cracking by shrinking the rim onto the spider, so that the rim does not slide on the rim ledge. On these machines, without a specific preload target, it can only be stated that the combination of measures did not prevent the movement. It is also noted that, as these are frictional forces due to sliding, the forces on the rim ledge due to startup and shutdown are of the same magnitude as high cycle forces that cause smaller movements.

The following patents, patent applications, patent publications, and other documents, except of the exceptions indicated herein, are hereby incorporated by reference as if set forth in their entirety herein except for the exceptions indicated herein, as follows: "The Use of Silver in Self-Lubricating Coatings for Extreme Temperatures" by Harold E. Sliney, prepared for the Annual Meeting of the American Society of Lubrication Engineers, Las Vegas, Nev., May 6-9, 1985; U.S. Pat. No. 8,333,006, having the title "Method for removing a crack in an electromechanical rotor", issued on Dec. 18, 2012; U.S. Pat. No. 7,866,020, having the title "Method for repairing a crack in an electromechanical rotor, method for preventing crack growth in the same, electro-mechanical rotor and rotary electrical machine", issued on Jan. 11, 2011; U.S. Pat. No. 4,636,675, having the title "Rotor spider for rotary electric machine", issued on Jan. 13, 1987; U.S. Pat. No. 4,327,303, having the title "Rotor assembly for a dynamoelectric machine", issued on Apr. 27, 1982; U.S. Pat. No. 4,283,648, having the title "Synchronous electric machine with salient poles in the rotor", issued on Aug. 11, 1981; U.S. Pat. No. 4,182,966, having the title "Ventilation system for dynamoelectric machines", issued on Jan. 8, 1980; U.S. Pat. No. 4,160,180, having the title "ROTOR LAMINATION SUPPORT FOR VERTICAL HYDRO-GENERATOR", issued on Jul. 3, 1979; U.S. Pat.



No. 4,110,652, having the title "Mounting assembly for laminated rotor rim of dynamoelectric generator rotatable about inclined shaft", issued on Aug. 29, 1978; U.S. Pat. No. 3,529,193, having the title "ROTOR FOR ELECTRIC MACHINE WITH VERTICAL SHAFT", issued on Sep. 15, 1970; U.S. Pat. No. 3,470,404, having the title "ROTORS FOR ROTATING ELECTRIC MACHINES", issued on Sep. 30, 1969; U.S. Pat. No. 3,112,420, having the title "Rotor construction for waterwheel driven electrical generator", issued on Nov. 26, 1963; U.S. Pat. No. 3,046,426, having the title "Rotor spider for electrical machines", issued on Jul. 24, 1962; U.S. Pat. No. 2,994,793, having the title "Dynamoelectric machine", issued on Aug. 1, 1962; U.S. Pat. No. 1,817,054, having title "Large, high speed rotor", issued on Aug. 4, 1931; Japanese patent document number 60-102829; and Japanese patent document number 54102501.

The components disclosed in the patents, patent applications, patent publications, and other documents disclosed or incorporated by reference herein, may possibly be used in possible embodiments of the present invention, as well as equivalents thereof.

The purpose of the statements about the technical field is generally to enable the Patent and Trademark Office and the public to determine quickly, from a cursory inspection, the nature of this patent application. The description of the technical field is believed, at the time of the filing of this patent application, to adequately describe the technical field of this patent application. However, the description of the technical field may not be completely applicable to the claims as originally filed in this patent application, as amended during prosecution of this patent application; and as ultimately allowed in any patent issuing from this patent application. Therefore, any statements made relating to the technical field are not intended to limit the claims in any manner and should not be interpreted as limiting the claims in any manner.

The appended drawings in their entirety, including all dimensions, proportions and/or shapes in at least one exemplification of the invention, are accurate and are hereby included by reference into this specification.

The background information is believed, at the time of the filing of this patent application, to adequately provide background information for this patent application. However, the background information may not be completely applicable to the claims as originally filed in this patent application, as amended during prosecution of this patent application, and as ultimately allowed in any patent issuing from this patent application. Therefore, any statements made relating to the background information are not intended to limit the claims in any manner and should not be interpreted as limiting the claims in any manner.

The invention claimed is:

1. A method for repairing a loss of support of a rim of a rotor during operation of an electrical generator, the rotor of the electrical generator being disposed for rotation about a vertical axis, the rotor comprising a shaft extending along the vertical axis, a spider attached to the shaft and extending radially away from the shaft, the spider having vertically spaced apart top and bottom sides with respect to the direction of gravity, the rim carrying poles and surrounding the spider, the weight of the rim normally being totally or partially supported on ledges disposed on the spider during normal operation of the electric generator, the loss of support of the rim being caused by mechanical failure or loss of at least a portion of the ledges, the method comprising:

fastening at least one support member on a top side of the rim adjacent the top side of the spider, each of the at least one support member extending away from the rim and over the top side of the spider,

wherein the at least one support member transfers at least a portion of the weight of the rim to the spider to support at least a portion of the rim against the top side of the spider and thereby relieve some or all of the weight of the rim being supported by the ledges without the need to repair any of the failed or lost portions of the ledges,

wherein the at least one support member comprises a plurality of thrust plates and fastening the at least one support member on the top side of the rim comprises fastening the plurality of thrust plates to the top side of the rim, the plurality of thrust plates being spaced apart from one another and extending over the top side of the spider.

2. The method for repairing of claim 1, further comprising:

disposing a wear plate between each of the plurality of thrust plates and the top side of the spider.

3. The method for repairing of claim 1, wherein fastening the plurality of thrust plates to the top side of the rim comprises:

fastening each thrust plate of the plurality of thrust plates by one or more screws extending through the thrust plate and being screwed into the top side of the rim.

4. A method for repairing a loss of support of a rim of a rotor during operation of an electrical generator, the rotor of the electrical generator being disposed for rotation about a vertical axis, the rotor comprising a shaft extending along the vertical axis, a spider attached to the shaft and extending radially away from the shaft, the spider having vertically spaced apart top and bottom sides with respect to the direction of gravity, the rim carrying poles and surrounding the spider, the weight of the rim normally being totally or partially supported on ledges disposed on the spider during normal operation of the electric generator, the loss of support of the rim being caused by mechanical failure or loss of at least a portion of the ledges, the method comprising:

fastening at least one support member on a top side of the rim adjacent the top side of the spider, each of the at least one support member extending away from the rim and over the top side of the spider,

wherein the at least one support member transfers at least a portion of the weight of the rim to the spider to support at least a portion of the rim against the top side of the spider and thereby relieve some or all of the weight of the rim being supported by the ledges without the need to repair any of the failed or lost portions of the ledges,

wherein the rim comprises a plurality of rim studs or rim bolts extending upwardly from the top side of the rim, and fastening the at least one support member on the top side of the rim comprises:

fastening each of the at least one support member to a respective set of at least one rim stud or rim bolt of the plurality of rim studs or rim bolts.

5. The method for repairing of claim 4, wherein the plurality of rim studs or rim bolts are threaded rim studs or threaded rim bolts, and fastening each of the at least one support member to a respective set of at least one rim stud or rim bolt comprises: threading a fastener onto each of at least one rim stud or rim bolt of each respective set.

6. A method for repairing a loss of support of a rim of a rotor during operation of an electrical generator, the rotor of

9

the electrical generator being disposed for rotation about a vertical axis, the rotor comprising a shaft extending along the vertical axis, a spider attached to the shaft and extending radially away from the shaft, the spider having vertically spaced apart top and bottom sides with respect to the direction of gravity, the rim carrying poles and surrounding the spider, the weight of the rim normally being totally or partially supported on ledges disposed on the spider during normal operation of the electric generator, the loss of support of the rim being caused by mechanical failure or loss of at least a portion of the ledges, the method comprising:

fastening at least one support member on a top side of the rim adjacent the top side of the spider, each of the at least one support member extending away from the rim and over the top side of the spider,

wherein the at least one support member transfers at least a portion of the weight of the rim to the spider to support at least a portion of the rim against the top side of the spider and thereby relieve some or all of the weight of the rim being supported by the ledges without the need to repair any of the failed or lost portions of the ledges,

wherein the spider comprises a plurality of spider arms extending from the shaft to the rim, and the at least one support member comprises a plurality of support members, wherein fastening the at least one support member on the top side of the rim comprises:

disposing each support member of the plurality of support members adjacent a respective spider arm and extending over the top side of each respective spider arm.

7. The method for repairing of claim 6, wherein each spider arm of the plurality of spider arms comprises a vertical post having top and bottom sides disposed on the top and bottom sides of the spider respectively, the ledges being disposed on the vertical posts, wherein fastening the at least one support member on the top side of the rim comprises:

disposing each support member of the plurality of support members adjacent to a respective vertical post of the plurality of spider arms, each support member extending over the top side of the respective vertical post.

8. A method for repairing a loss of support of a rim of a rotor during operation of an electrical generator, the rotor of the electrical generator being disposed for rotation about a vertical axis, the rotor comprising a shaft extending along the vertical axis, a spider attached to the shaft and extending radially away from the shaft, the spider having vertically spaced apart top and bottom sides with respect to the direction of gravity, the rim carrying poles and surrounding the spider, the weight of the rim normally being totally or partially supported on ledges disposed on the spider during normal operation of the electric generator, the loss of support of the rim being caused by mechanical failure or loss of at least a portion of the ledges, the method comprising:

fastening at least one support member on a top side of the rim adjacent the top side of the spider, each of the at least one support member extending away from the rim and over the top side of the spider,

wherein the at least one support member transfers at least a portion of the weight of the rim to the spider to support at least a portion of the rim against the top side of the spider and thereby relieve some or all of the weight of the rim being supported by the ledges without the need to repair any of the failed or lost portions of the ledges,

wherein the rim comprises a plurality of rim studs or rim bolts extending upwardly from the top side of the rim, the spider comprises a plurality of spider arms extend-

10

ing between the shaft and the rim, and the at least one support member comprises a plurality of thrust plates, wherein fastening the at least one support member on the top side of the rim comprises: disposing each of the plurality of thrust plates on the top side of the rim adjacent to a respective spider arm, each thrust plate of the plurality of thrust plates extending over the top side of the respective spider arm;

disposing a wear plate between each of the plurality of thrust plates and the top side of the respective spider arm; and

fastening each thrust plate of the plurality of thrust plates to the top side of the rim by fastening the thrust plate to a set of two or more rim studs or rim bolts with sleeve bolts.

9. A method for repairing a loss of support of a rim of a rotor during operation of an electrical generator, the rotor of the electrical generator being disposed for rotation about a vertical axis, the rotor comprising a shaft extending along the vertical axis, a spider attached to the shaft and extending radially away from the shaft, the spider having vertically spaced apart top and bottom sides with respect to the direction of gravity, the rim carrying poles and surrounding the spider, the weight of the rim normally being totally or partially supported on ledges disposed on the spider during normal operation of the electric generator, the loss of support of the rim being caused by mechanical failure or loss of at least a portion of the ledges, the method comprising:

fastening at least one support member on a top side of the rim adjacent the top side of the spider, each of the at least one support member extending away from the rim and over the top side of the spider,

wherein the at least one support member transfers at least a portion of the weight of the rim to the spider to support at least a portion of the rim against the top side of the spider and thereby relieve some or all of the weight of the rim being supported by the ledges without the need to repair any of the failed or lost portions of the ledges,

wherein fastening the at least one support member on the top side of the rim adjacent the top side of the spider is done while the rotor is at a standstill, wherein the rim and the spider cooperatively define an interference fit therebetween while the rotor is at the standstill such that a frictional force resisting vertical movement of the rim with respect to the spider is generated.

10. A method for repairing a loss of support of a rim of a rotor during operation of an electrical generator, the rotor of the electrical generator being disposed for rotation about a vertical axis, the rotor comprising a shaft extending along the vertical axis, a spider attached to the shaft and extending radially away from the shaft, the spider having vertically spaced apart top and bottom sides with respect to the direction of gravity, the rim carrying poles and surrounding the spider, the weight of the rim normally being totally or partially supported on ledges disposed on the spider during normal operation of the electric generator, the loss of support of the rim being caused by mechanical failure or loss of at least a portion of the ledges, the method comprising:

fastening at least one support member on a top side of the rim adjacent the top side of the spider, each of the at least one support member extending away from the rim and over the top side of the spider,

wherein the at least one support member transfers at least a portion of the weight of the rim to the spider to support at least a portion of the rim against the top side of the spider and thereby relieve some or all of the

11

weight of the rim being supported by the ledges without the need to repair any of the failed or lost portions of the ledges,

wherein prior to fastening the at least one support member on the top side of the rim adjacent the top side of the spider, the rim floats with respect to the spider during normal operation of the electric generator.

11. A method for repairing a loss of support of a rim of a rotor during operation of an electrical generator, the rotor of the electrical generator being disposed for rotation about a vertical axis, the rotor comprising a shaft extending along the vertical axis, a spider attached to the shaft and extending radially away from the shaft, the spider having vertically spaced apart top and bottom sides with respect to the direction of gravity, the rim carrying poles and surrounding the spider, the weight of the rim normally being totally or partially supported on ledges disposed on the spider during normal operation of the electric generator, the loss of support

12

of the rim being caused by mechanical failure or loss of at least a portion of the ledges, the method comprising:

fastening at least one support member on a top side of the rim adjacent the top side of the spider, each of the at least one support member extending away from the rim and over the top side of the spider,

wherein the at least one support member transfers at least a portion of the weight of the rim to the spider to support at least a portion of the rim against the top side of the spider and thereby relieve some or all of the weight of the rim being supported by the ledges without the need to repair any of the failed or lost portions of the ledges,

wherein the rim is lifted off the ledges after fastening the at least one support member on the top side of the rim adjacent the top side of the spider.

\* \* \* \* \*